







**TOTAL BEVERAGE CHOICE, ON TAP**

**ORDER CODES** (Complete bundle)

POUR'D Concentrate 3b  
5000940C3B

FONT	CONTROL BOX	BOILER	CHILLER / CARBONATOR	
		OPTIONAL MIX UC3	OPTIONAL FRIIA	OPTIONAL FRIIA LITE
				
<ul style="list-style-type: none"> <li>&gt; POUR'D can be used to dispense beverages from any concentrate or syrup source.</li> </ul>		<ul style="list-style-type: none"> <li>&gt; To dilute with hot water, or</li> <li>&gt; To add separate hot water</li> </ul>	<ul style="list-style-type: none"> <li>&gt; To dilute with either chilled or sparkling water</li> <li>&gt; To add separate chilled/sparkling water</li> </ul>	

DRINK OPTIONS

POUR'D can be used with:  
Concentrates & Syrups with Max Viscosity of 700 CPS

**BEVERAGE IDEAS** (from concentrate):

- > Cold coffee
- > Hot coffee (Americano style)
- > Shot coffee concentrate for iced mochas / lattes
- > Sparkling lemonade
- > Iced tea

Minimum 4ml concentrate to 125ml final beverage

Option to add hot water for tea, americano, hot chocolate



POUR'D SET-UP

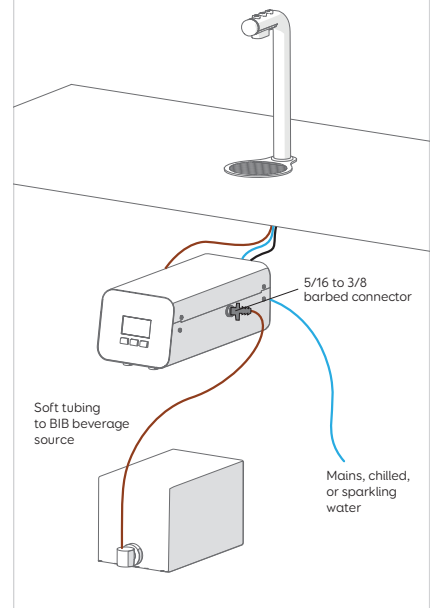

RECOMMENDED DILUTION RATIOS: 5:1 — Hot 

1:1 - 30:1 — Cold/Sparkling 

# PRODUCT SPECS & PACKAGING INFORMATION



PRODUCT SPECS

	FONT	CONTROL BOX	BOILER	CHILLER / CARBONATOR	
	3B POUR'D FONT 1000942	POUR'D Control Box 1000944	MIX UC3 1000880	FRIIA 1000860 / 1000861	FRIIA Lite 1000201 / 1000202
Dimensions (D x W x H mm)	168 x 125 x 287 (Incl. drip tray)	399 x 157 x 140 (width not including tubing)	385 x 210 x 444	436 x 259 x 455	468 x 279 x 420
Power	—	230v 40W	230V 2.8kW	230V 200W	230V 220W
Plumbing	—	3/4" BSP	3/4" BSP	3/4" BSP	3/4" BSPM
L/HR	—	126L	28L	30-40/hr based on incoming water temp of 15°C and output water temp of 5-7°	12L/hr based on incoming water temp of 15°C and output water temp of 5-7°
Performance Specs	—	Dilution Range: 1:1 - 30:1	Immediate Draw Off: 3L	Cups/HR: 175-235 (ΔT = 10 °C)	Cups/HR: 60
Compressor Power	—	—	—	1/8hp	129 W
Charge	—	—	—	45g	35g
Refrigerant	—	—	—	R290	R600a/35g

PACKAGING

ITEM	PACKAGING DIMENSIONS (L x W x H mm)	WEIGHT	QTY / PALLET
Font	290 x 570 x 215	2kg	54
Control Box	419 x 260 x 330	5.6kg	48/36 (sea/air freight)
MIX UC3	450 x 290 x 540	11kg	24
FRIIA Chiller/Carbonator	590 x 385 x 520	35kg	5
FRIIA Lite Chiller/Carbonator	590 x 385 x 520	21.2kg	

POUR'D CAN DILUTE/DISPENSE:

Non-Dairy Milks	✓	Dairy Milk	✗
Syrups	✓	Thick Syrup/Molasses (>700 CPS)	✗
Concentrates	✓	Kombucha	✗
Juice (no pulp, <700 CPS)	✓	Powder	✗
RTD Cold Drinks	✓	RTD Hot Drinks	✗



## POUR'D CONCENTRATE 3B 5000940C3B

### Mains Water or Chilled Water from FRIIA

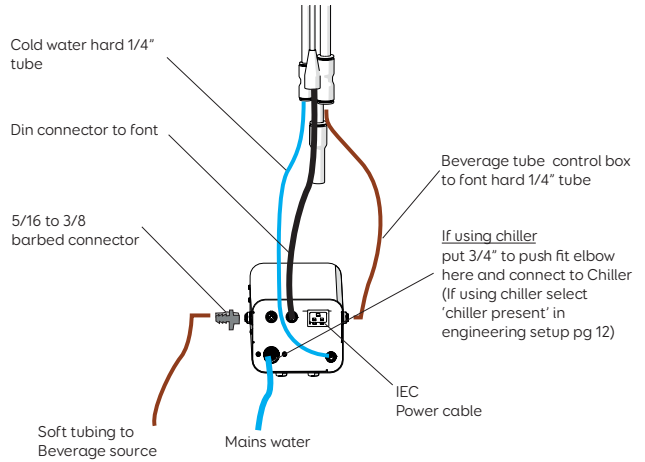
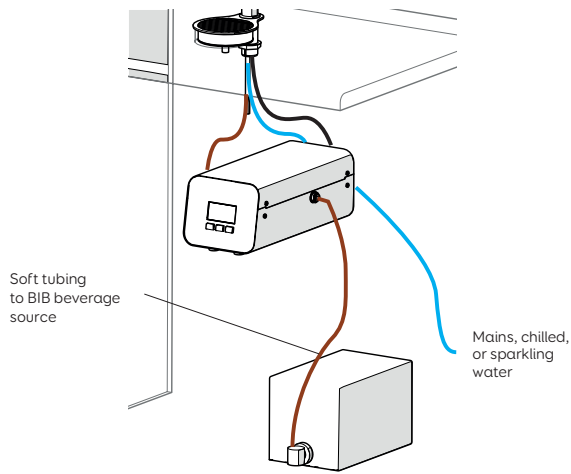

### Mains Water + Hot Water Boiler

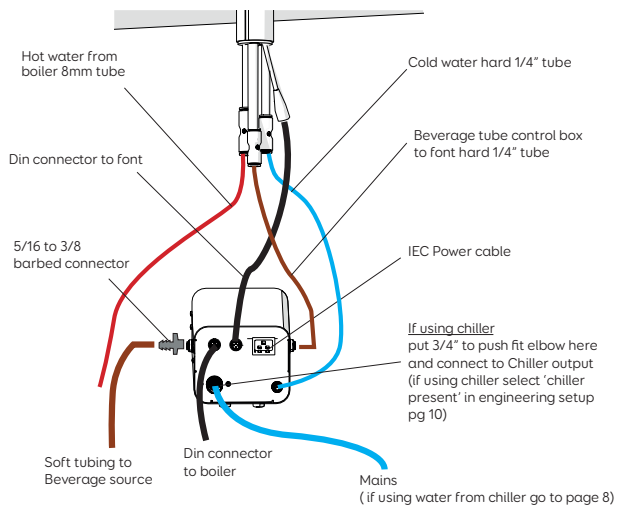
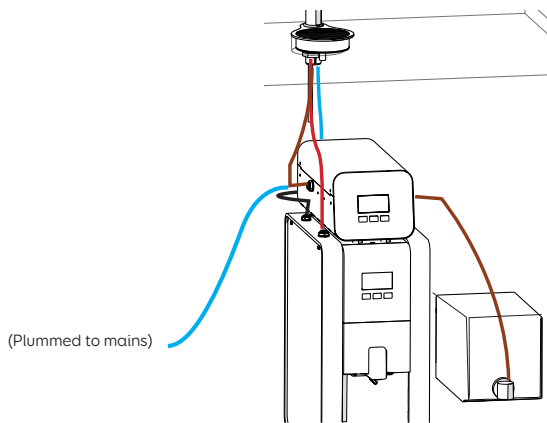

# RECOMMENDED SET-UP & CLEARANCE REQUIREMENTS



POUR'D

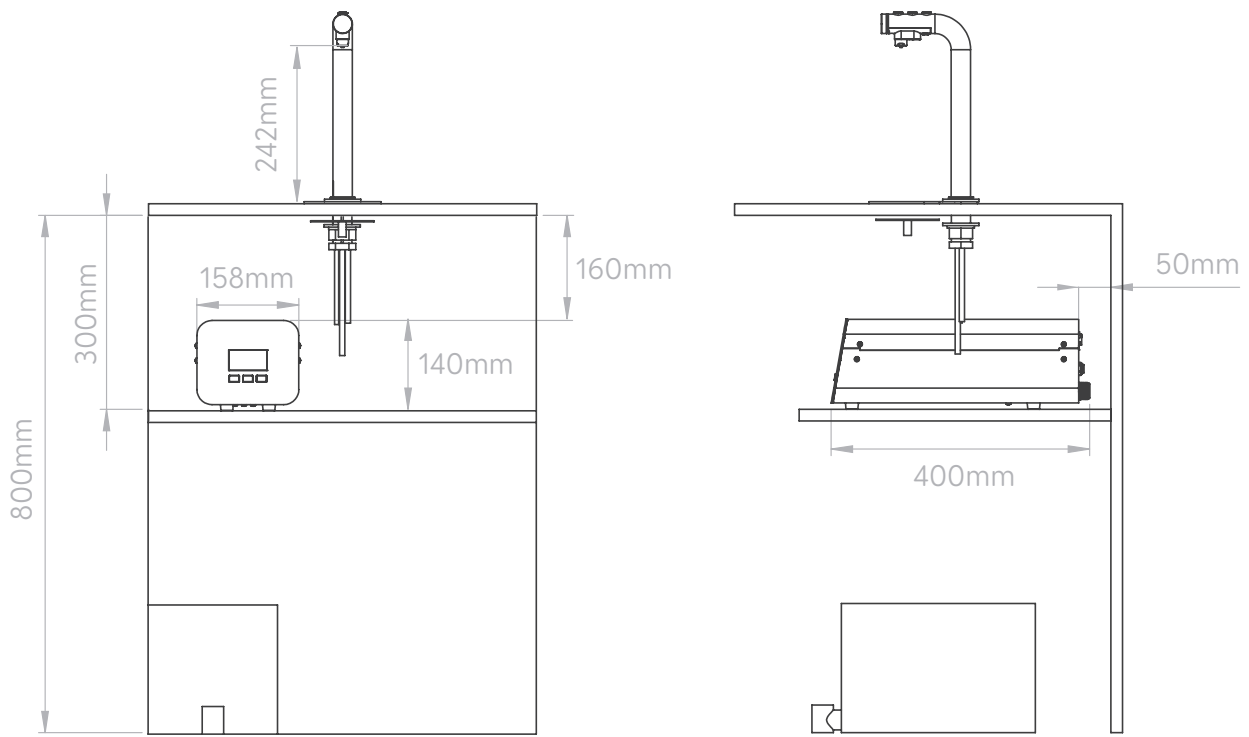

# RECOMMENDED SET-UP & CLEARANCE REQUIREMENTS



POUR'D WITH MIX UC3

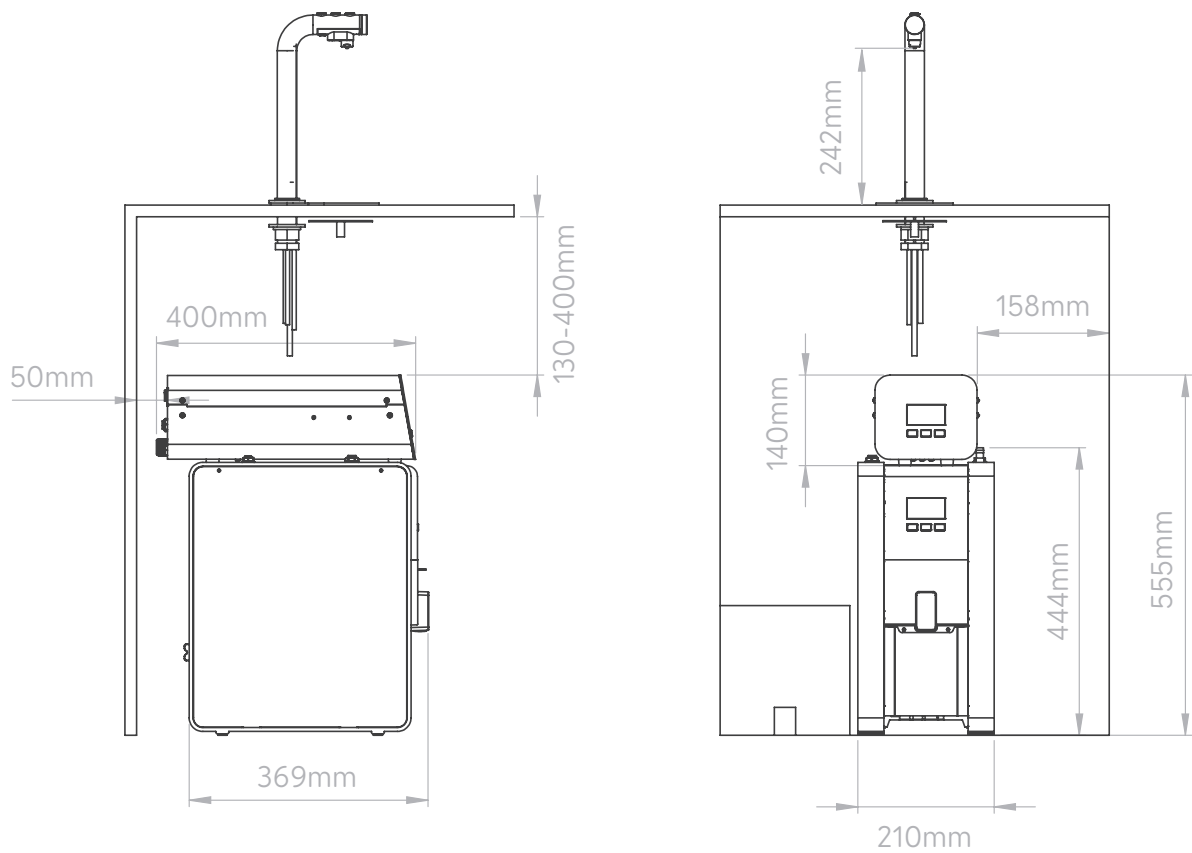

# RECOMMENDED SET-UP & CLEARANCE REQUIREMENTS



## POUR'D WITH FRIIA

